

PARTS LIST

Vacuum Cleaner

SC-18(L) (U.S.A.)

Specifications

Power source	: AC 120 V 60 Hz	
Power consumption	: 5.5 A	
Motor revolution	: 32,500 r.p.m.	
Vacuum	: 2,000 mmAq	
Dimensions	(Handy)	(Upright)
L X W X H	13 - 19/32" X 7 - 3/32" X 8 - 27/32" (354 X 180 X 225 mm)	14 - 3/16" X 11 - 13/16" X 43 - 5/16" (360 X 300 X 1,100 mm)
Net weight	: 8 lbs. 6 ozs. (3.8 Kg)	
Attachment	: Hose, Turbine brush, Extension pipe, Crevice tool, Upholstery tool & Dusting brush	

PRODUCT CODE NO.

1 - 326 579 52 (L)

Wiring Diagram

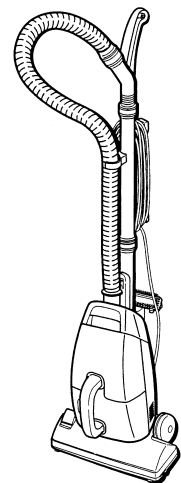
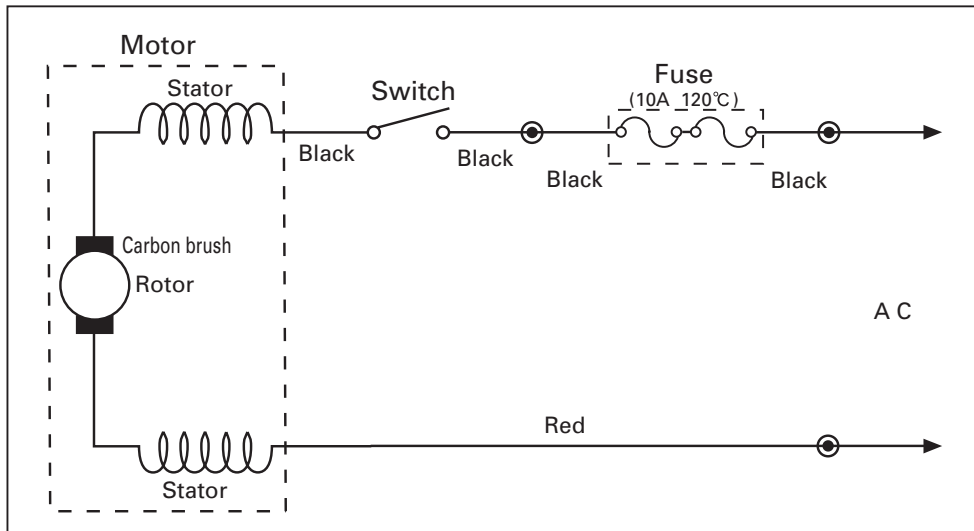

**Exploded View
(Main unit)**

NOTE: The parts marked with Δ have special characteristics of safety,
if replace the Δ mark parts, use only SANYO specified parts.

SC-18(L) (U.S.A.)

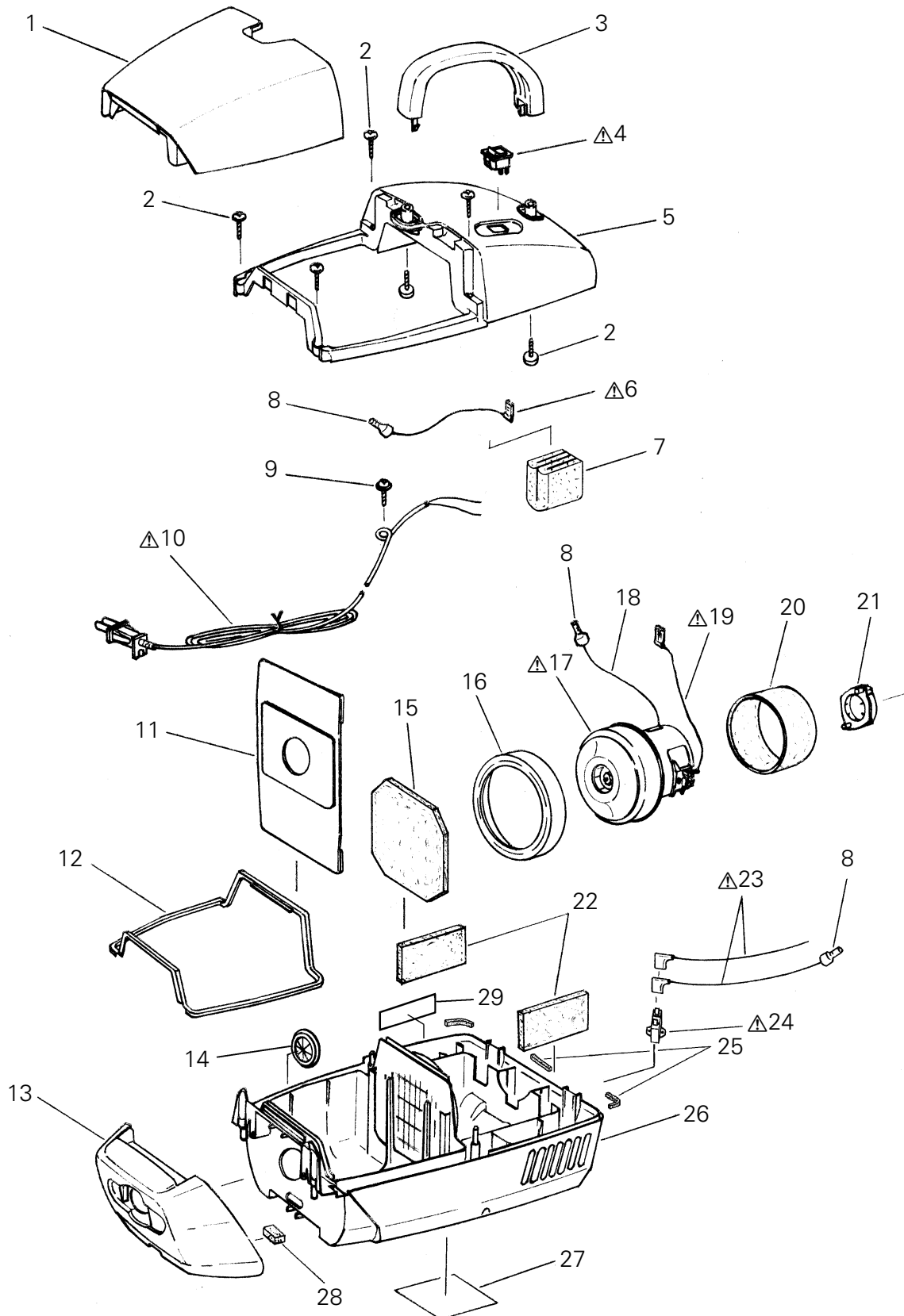

**Exploded View
(Attachment)**

SC-18(L) (U.S.A.)

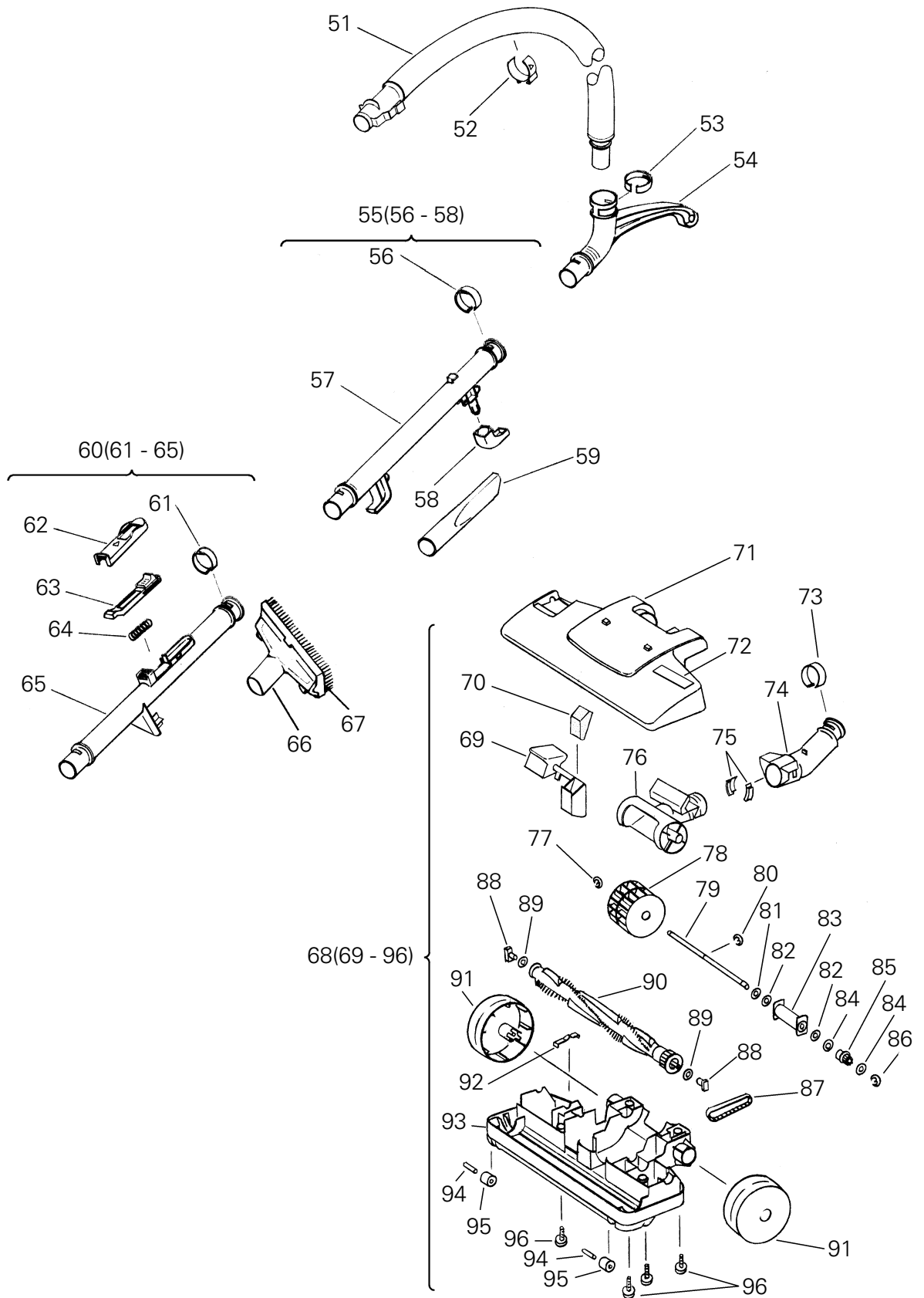

Parts List

NOTE: The parts marked with \triangle have special characteristics of safety,
if replace the \triangle mark parts, use only SANYO specified parts.

SC-18(L) (U.S.A.)

Key No.	Parts No.	Description	Q'ty	Key No.	Parts No.	Description	Q'ty
	(Main unit)				(Attachment)		
1	649 000 4740	DUST BOX COVER (B-474)	1	51	649 000 3347	HOSE ASSEMBLY (L=750)	1
2	411 006 8301	SCR TPG PAN 4X20	6	52	649 000 3354	HOSE HOLDER (NN-B)	1
3	649 000 3132	HANDLE (NN-B)	1	53	649 000 4764	ROTARY BEND SET RING (B-474)	1
\triangle 4	649 000 3149	SWITCH	1	54	649 000 3378	GRIP (NN-B)	1
5	649 000 4757	CASE UPPER (B-474)	1	55	649 000 4771	EXTENSION PIPE ASSEMBLY B KEYNO.56-58	1
\triangle 6	649 000 3163	CORD ASSEMBLY (BLACK) L=300	1	56	649 000 4788	PIPE SET RING (B-474)	1
7	649 000 2586	SUB-FILTER	1	57	649 000 3408	EXTENSION PIPE B (NN-B)	1
8	649 000 0520	WIRE CONNECTOR (CE-230)	3	58	649 000 3415	CORD STORAGE HOOK (NN-B)	1
9	649 000 2654	SCREW 4X16	1	59	649 000 3422	CREVICE TOOL (NN-B)	1
\triangle 10	649 000 3170	POWER CORD (UL)	1	60	649 000 4795	EXTXNSION PIPE ASSEMBLY A KEYNO.61-65	1
11	649 000 3187	PAPER BAG (SC-P11)	1	61	649 000 4788	PIPE SET RING (B-474)	1
12	649 000 3194	DUST BOX PACKING	1	62	649 000 3446	PIPE COVER (NN-B)	1
13	649 000 3200	FRONT COVER (NN-B)	1	63	649 000 4801	BUTTON (PIPE) (B-474)	1
14	649 000 3217	AIR INLET PACKING (NN-B)	1	64	649 000 3460	CLAMP SPRING	1
15	649 000 3224	ELECTROSTATIC MICRON FILTER	1	65	649 000 3873	EXTENSION PIPE A (NN-B)	1
16	649 000 3231	MOTOR CUSHION FRONT	1	66	649 000 2159	UPHOLSTERY TOOL (NN-B)	1
\triangle 17	649 000 3774	MOTOR COMP. (AC 120V)	1	67	649 000 2814	DUSTING BRUSH (NN-B)	1
\triangle 18	649 000 3255	CARBON BRUSH ASSEMBLY	2	68	649 000 4818	TURBINE BRUSH COMP. KEYNO.69-96	1
19	649 000 3262	LEAD WIRE (RED) L=250	1	69	649 000 3897	LEVER (NN-B)	1
\triangle 20	649 000 3279	CORD ASSEMBLY (BLACK) L=350	1	70	649 000 3903	AIR SPREADER	1
21	649 000 3286	SILENCER PIPE	1	71	649 000 4825	TURBINE BRUSH CASE(B-474)	1
22	649 000 3293	MOTOR CUSHION REAR	1	72	649 000 3927	CAUTION LABEL	1
23	649 000 3798	OUTLET FILTER	2	73	649 000 4788	PIPE SET RING (B-474)	1
\triangle 24	649 000 1800	CORD ASSEMBLY (BLACK) L=200	2	74	649 000 3507	ROTARY BEND (NN-B)	1
\triangle 25	649 000 3606	FUSE ASS'Y (10A 120°C)	1	75	649 000 3514	BEND SET PIECE (NN-B)	2
26	649 000 0643	AIR SPREADER G	3	76	649 000 3521	ROTARY PIPE (NN-B)	1
27	649 000 3316	CASE LOWER (NN-B)	1	77	411 001 0003	RING E 4	1
28	649 000 3804	NAME PLATE	1	78	649 000 3934	FAN ASSEMBLY	1
29	649 000 3330	INDICATOR FILTER	1	79	649 000 3941	TURBINE FAN SHAFT	1
	649 000 3811	CAUTION LABEL	1	80	411 001 1307	RING U 5	1
				81	411 009 5505	WASHER Z 6.2X12X0.5	1
				82	649 000 3958	WASHER 6.2X12X0.5	2
				83	649 000 3965	RESIN SLEEVE ASSEMBLY LARGE	1
				84	411 091 3700	WASHER Y 6.2X12X0.5	2
				85	649 000 3972	TURBINE FAN PULLEY	1
				86	411 001 0201	RING E 5	1
				87	649 000 3989	TIMING BELT	1
				88	649 000 3996	BRUSH BASE BEARING	2
				89	649 000 4009	WASHER 4.2X10X0.5	2
				90	649 000 4016	AGITATOR ASSEMBLY	1
				91	649 000 3538	FLOOR NOZZLE ROLLER (NN-B)	2
				92	649 000 4023	LEAF SPRING	1
				93	649 000 4030	TURBINE BRUSH BASE(NN-B)	1
				94	649 000 4047	SHAFT FRONT	2
				95	649 000 4054	WHEEL SMALL ASSEMBLY (NN-B)	2
				96	411 006 8301	SCR TPG PAN 4X20	4

COLOR CODE:B-474(BLUE),NN-B(BLACK)

For Parts or Service Contact
SANYO FISHER SERVICE CORPORATION.
21605 Plummer Street,
Chatsworth, CA 91311